

ARTICLE BEGINNING

2000-01 GENERAL SERVICING
General Servicing Procedures

USING R-134a REFRIGERANT

NOTE: For additional GENERAL SERVICING information, see the latest MITCHELL(R) AUTOMOTIVE AIR CONDITIONING BASIC SERVICE TRAINING MANUAL.

HANDLING/SAFETY PRECAUTIONS

- * Always work in a well-ventilated, clean area. Refrigerant is colorless and invisible as a gas. Refrigerant is heavier than oxygen and will displace oxygen in a confined area. Avoid breathing refrigerant vapors. Exposure may irritate eyes, nose and throat.
- * Always wear eye protection when working around A/C system and refrigerant. The system's high pressure can cause severe injury to eyes and skin if a hose were to burst. If necessary, wear rubber gloves or other protective clothing.
- * Refrigerant evaporates quickly when exposed to atmosphere, freezing anything it contacts. If liquid refrigerant contacts eyes or skin (frostbite), DO NOT rub eyes or skin. Immediately flush affected area with cool water for 15 minutes and consult a doctor or hospital.
- * Never use R-134a in combination with compressed air for leak testing. Pressurized R-134a in the presence of oxygen (air concentrations greater than 60 percent by volume) may form a combustible mixture. DO NOT introduce compressed air into R-134a containers (full or empty), A/C system components, or service equipment.
- * DO NOT expose A/C system components to high temperatures (steam cleaning for example), as excessive heat will cause refrigerant system pressure to increase. Never expose refrigerant directly to open flame. If refrigerant needs to be warmed, place bottom of refrigerant tank in warm water. Water temperature must not exceed 125øF (52øC).

CAUTION: When R-134a is exposed to an open flame, drawn into engine, or detected with a Halide (propane) leak tester, a poisonous gas is formed. Keep work areas well ventilated.

- * Use care when handling refrigerant containers. DO NOT drop, strike, puncture, or incinerate containers. Use DOT 4BW or DOT 4BA approved refrigerant containers.
- * Never overfill refrigerant containers. The safe filling level of a refrigerant container MUST NOT exceed 60 percent of the container's gross weight rating. Store refrigerant containers at temperatures less than 125øF

- (52°C).
- * R-134a refrigerant is sold and stored in 30- or 50-pound Light Blue containers, while Freon (R-12) is stored in White colored containers.
 - * Refrigerant R-12 and R-134a must never be mixed, as they and their desiccants and lubricants are not compatible. If the refrigerants are mixed, system cross-contamination or A/C system component failure may occur. Always use separate servicing and refrigerant recovery/recycling equipment.
 - * Read and follow equipment manufacturer's instructions for all service equipment to be used. The Material Safety Data Sheet (MSDS), provided by refrigerant manufacturer/supplier, contains valuable information regarding the safe handling of refrigerants.

IDENTIFYING R-134a SYSTEMS & COMPONENTS

To prevent refrigerant cross-contamination, use following methods to identify R-134a based systems and components.

Fittings & "O" Rings

All R-134a based A/C systems use 1/2" - 16 ACME threaded fittings (identifiable by square threads) and quick-connect service ports. See Fig. 1.

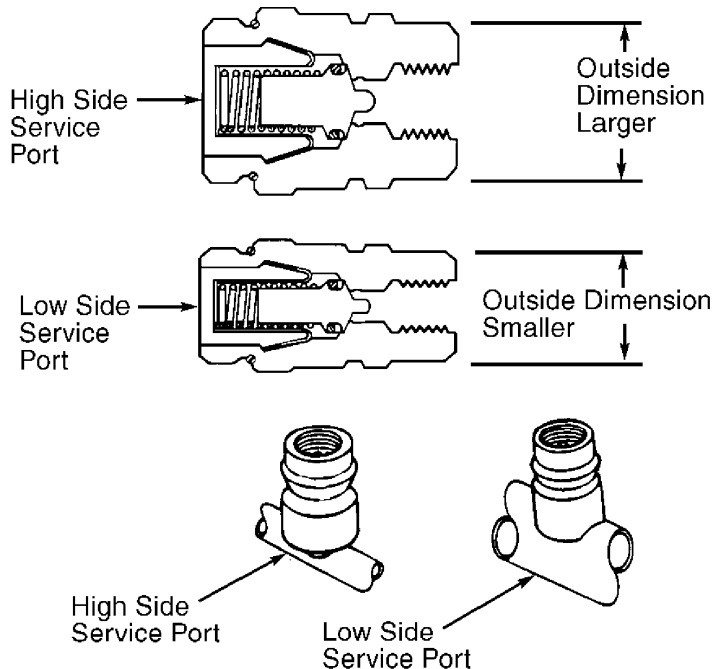

93I28488

Fig. 1: Identifying R-134a Service Ports
Courtesy of DaimlerChrysler Corp.

Underhood A/C Specification Labels

Most R-134a based systems will be identified through the use

ABC123

Entire Article
2000 Chevrolet Camaro

of underhood labels with R-134a refrigerant clearly printed on labels. See Fig. 2. The underhood label used on Ford Motor Co. vehicles is Yellow. See Fig. 3. Most manufacturers will identify refrigerant type with labels affixed to compressor. Before servicing an A/C system, always determine which refrigerant is being used.

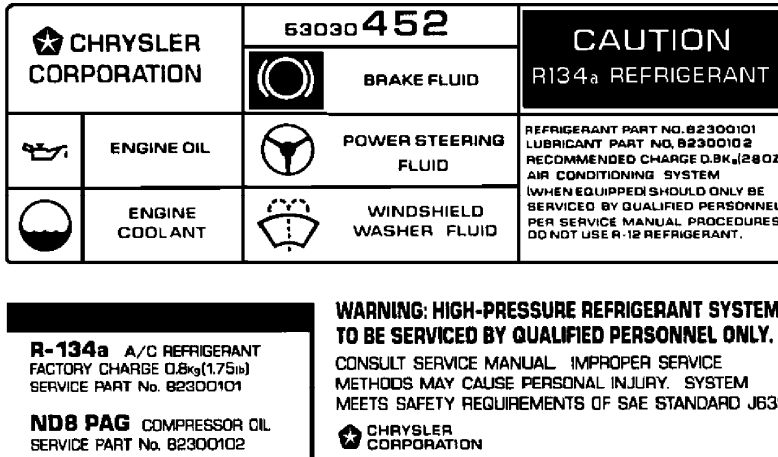

93D28483

Fig. 2: Underhood Refrigerant Identification Label (Typical Dai ml erChrysl er Corp.)
Courtesy of Dai ml erChrysl er Corp.

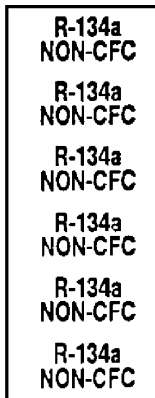

93E28484

Fig. 3: Underhood Refrigerant Identification Label (Typical Ford Motor Co.)
Courtesy of Ford Motor Co.

REFRIGERANT OILS

Refrigerant R-12 based systems use mineral oil, while R-134a systems use synthetic Polyalkylene Glycol (PAG) oils. Using a mineral oil based lubricant with R-134a will result in A/C compressor failure due to lack of proper lubrication.

Following are the most common R-134a refrigerant oils used by most domestic vehicles:

DaimlerChrysler Corp. & Jeep
Use ND-8 PAG oil, SUN PAG 56 oil, SP-10 PAG Oil, SP-15 PAG Oil, or SP-20 PAG oil.

Ford Motor Co.
Use YN-12B or YN-12C PAG Refrigerant Oil (specification WSH-M1C231-B) or SP-20 PAG Oil (specification WST-M1C231-B2).

General Motors
On all models except Saturn, use PAG Refrigerant Oil (Part No. 12345923). On Saturn, use Saturn PAG refrigerant oil.

NOTE: PAG oil absorbs moisture very rapidly, 2.3-5.6 percent by weight as compared to a mineral oil absorption rate of 0.005 percent by weight.

NOTE: Use ONLY the specified oil for the appropriate system or A/C compressor. Always check the underhood A/C specification label or A/C compressor label before adding refrigerant oil to A/C system.

SYSTEM SERVICE VALVES

SCHRADER-TYPE VALVES

NOTE: Although similar in construction and operation to a tire valve, NEVER replace a Schrader-type valve with a tire valve.

Schrader valve is similar in construction and operation to a tire valve. See Fig. 4. When a test gauge hose is attached (hose has built-in valve core depressor), Schrader stem is pushed inward to the open position and allows system pressure to reach the gauge.

If test hose being used does not have a built-in core depressor, an adapter must be used. Never attach hoses or adapters to a Schrader valve unless it is first connected to manifold gauge set.

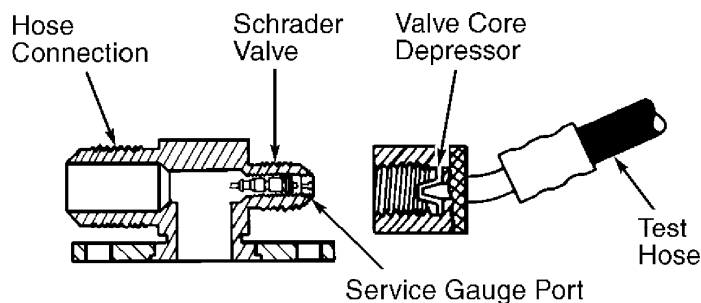

95A17640

Fig. 4: Schrader Service Valve (Compressor Location Shown)

SPECIAL VALVE CONNECTORS

On some General Motors models, thread size on high-side

service valve (3/8" - 24 threads) is different from thread size on low-side service valve (7/16" - 20 threads). Special adapters are required to make this connection. See Fig. 5. These adapters are available in 45-degree and 90-degree angles in addition to straight-fixed and flexible adapters.

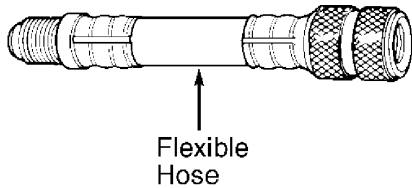

95B17641

Fig. 5: Flexible High Side Adapter

R-134a SERVICE VALVES/PORTS

All vehicles with R-134a refrigerant use quick-disconnect service valves/ports. All R-134a systems use quick-disconnect fittings with sealing caps that thread into inside of service port instead of onto outside of service port.

The high side uses a large service port, and the low side uses a small service port. See Fig. 1. The R-134a service ports have internal metric threads to help prevent the accidental connection of R-12 servicing equipment.

There are 2 types of quick-disconnect service couplings which can be used on R-134a systems. One type of service coupling depresses service port valve when connection is made. The other type connects onto service port but will not depress service port valve until a knob is rotated. See Fig. 6.

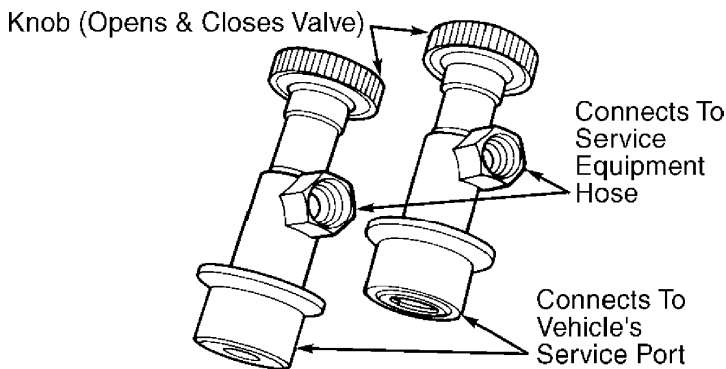

95C17642

Fig. 6: R-134a Service Couplings
Courtesy of DaimlerChrysler Corp.

SERVICE VALVE LOCATIONS

For service valve locations, see SERVICE VALVE LOCATIONS (CARS) or SERVICE VALVE LOCATIONS (TRUCKS & VANS) table.

A/C SYSTEM GENERAL SERVICING

ABC123

Entire Article
2000 Chevrolet Camaro

SERVICE VALVE LOCATIONS (CARS)

AA

Vehi cl e	Hi gh	Low
-----------	-------	-----

2000

Dai ml erChrysl er Corp.

Avenger & Sebring Coupe	(1)	(2)
Breeze, Cirrus & Stratus	(7)	(4)
Concorde, Intrepid, LHS & 300M		
2.7L	(3)	(4)
3.2L & 3.5L	(5)	(6)
Neon	(13)	(4)
Sebring Convertible	(7)	(4)

Ford Motor Co.

Conti nental	(9)	(10)
Contour, Cougar & Mystique		
2.0L Engi ne	(7)	(11)
2.5L Engi ne	(7)	(12)
Crown Victoria, Grand Marqui s & Town Car	(7)	(13)
Escort	(8)	(10)
Focus	(3)	(4)
LS	(13)	(5)
Mustang	(7)	(13)
Sabl e & Taurus	(8)	(11)

General Motors

"C" Body	(3)	(15)
"E" & "K" Bodi es	(3)	(15)
"F" Body	(9)	(4)
"G" Body	(3)	(15)
"H" Body	(7)	(12)
"J" Body	(7)	(12)
"M" Body	(9)	(4)
"N" Body	(9)	(4)
"S" Body	(9)	(4)
"V" Body	(9)	(4)
"W" Body	(9)	(4)
"Y" Body	(3)	(12)
Saturn "J" Body	(9)	(11)
Saturn "Z" Body	(5)	(5)

2001

Dai ml erChrysl er Corp.

Concorde, Intrepid, LHS & 300M		
2.7L	(3)	(4)
3.2L & 3.5L	(5)	(6)
Neon	(13)	(4)
Sebring Convertible	(7)	(4)
Sebring Coupe & Stratus Coupe	(1)	(2)
Sebring Sedan & Stratus Sedan	(7)	(4)

Ford Motor Co.

Conti nental	(9)	(10)
Cougar		
2.0L Engi ne	(7)	(11)
2.5L Engi ne	(7)	(12)

A/C SYSTEM GENERAL SERVICING

ABC123

Entire Article
2000 Chevrolet Camaro

Crown Victoria, Grand Marquis & Town Car	(7)	(13)
Escort	(8)	(10)
Focus	(3)	(4)
LS	(13)	(5)
Mustang	(7)	(13)
Sable & Taurus	(8)	(11)
General Motors		
"C" Body	(3)	(15)
"E" & "K" Bodies	(3)	(15)
"F" Body	(9)	(4)
"G" Body	(3)	(15)
"H" Body	(7)	(12)
"J" Body	(7)	(12)
"M" Body	(9)	(4)
"N" Body	(9)	(4)
"S" Body	(9)	(4)
"V" Body	(9)	(4)
"W" Body	(9)	(4)
"Y" Body	(3)	(12)
Saturn "J" Body	(9)	(11)
Saturn "Z" Body	(5)	(5)

- (1) - On high-side liquid line, between receiver-drier and evaporator.
- (2) - On low-side hose between evaporator and compressor.
- (3) - On high-side liquid line.
- (4) - On low-side suction line.
- (5) - On top of compressor manifold.
- (6) - On compressor manifold, closest to compressor clutch.
- (7) - On high-side line, between compressor and condenser.
- (8) - On extension of high-side line, between condenser and evaporator.
- (9) - On high-side line (or extension), near condenser.
- (10) - On low-side line (or extension), near accumulator.
- (11) - On low-side line, between evaporator and accumulator/receiver-drier.
- (12) - On low-side line, between accumulator/receiver-drier and compressor.
- (13) - On accumulator/receiver-drier.
- (14) - On high-side line, near condenser.
- (15) - On low-side line, between orifice tube and evaporator.

AA

SERVICE VALVE LOCATIONS (TRUCKS & VANS)

AA

Vehi cle	Hi gh	Low
----------	-------	-----

2000

Dai ml erChrysl er Corp.		
Caravan, Town & Country, & Voyager	(1)	(2)
Dakota	(3)	(4)
Durango	(3)	(4)
Ram Pi ckup	(3)	(5)
Ram Van/Wagon	(6)	(7)
Ford Motor Co.		

A/C SYSTEM GENERAL SERVICING

ABC123

Entire Article
2000 Chevrolet Camaro

"E" Series	(6)	(8)
Explorer, Mountaineer & Ranger	(6)	(9)
F150, Expedition & Navigator	(6)	(9)
Excursion, F250, F350 & Super Duty	(6)	(5)
Villager	(10)	(5)
Windstar	(11)	(9)
General Motors		
"C" & "K" Series	(4)	(9)
"E" & "J" Series	(9)	(15)
"G" Series	(12)	(9)
"L" & "M" Series	(12)	(5)
"P" Series	(14)	(15)
"S" & "T" Series	(16)	(9)
"U" Series	(1)	(5)
Jeep		
Cherokee	(6)	(17)
Grand Cherokee	(18)	(15)
Wrangler	(18)	(19)
2001		
DaimlerChrysler Corp.		
Caravan, Town & Country, & Voyager	(1)	(2)
Dakota	(3)	(4)
Durango	(3)	(4)
Ram Pickup	(3)	(5)
Ram Van & Ram Wagon	(6)	(7)
Ford Motor Co.		
"E" Series	(6)	(8)
Escape	(3)	(5)
Explorer, Mountaineer & Ranger	(6)	(9)
F150, Expedition & Navigator	(6)	(9)
Excursion, F250, F350 & Super Duty	(6)	(5)
Villager	(10)	(5)
Windstar	(11)	(9)
General Motors		
"C" & "K" Series	(4)	(9)
"E" & "J" Series	(9)	(15)
"G" Series	(12)	(9)
"L" & "M" Series	(12)	(5)
"P" Series	(14)	(15)
"S" & "T" Series	(16)	(9)
"U" Series	(1)	(5)
Jeep		
Cherokee	(6)	(17)
Grand Cherokee	(18)	(15)
Wrangler	(18)	(19)

- (1) - On high-side line, near right frame rail. See Fig. 7.
- (2) - On low-side line, near compressor. See Fig. 7.
- (3) - On high-side line, between condenser and evaporator, near front of engine compartment.
- (4) - On compressor manifold.
- (5) - On low-side line, near accumulator.
- (6) - On high-side line, between compressor and condenser, near front of engine compartment.

A/C SYSTEM GENERAL SERVICING

ABC123

Entire Article
2000 Chevrolet Camaro

- (7) - On low-side line extension, near receiver-drier, at front of engine compartment.
- (8) - On low-side line from accumulator, near windshield washer reservoir.
- (9) - On accumulator/receiver-drier.
- (10) - On high-side line extension from compressor.
- (11) - On high-side line, between compressor and condenser, near accumulator. See Fig. 8.
- (12) - On high-side line between evaporator and condenser, near evaporator.
- (13) - On low-side (suction) line, near compressor.
- (14) - On high-side inlet line, at evaporator.
- (15) - On low-side outlet line, at evaporator.
- (16) - On high-side line.
- (17) - On low-side (suction) line, between accumulator outlet and compressor.
- (18) - Discharge line, near compressor.
- (19) - On liquid line, near evaporator inlet, at rear of engine compartment.

AA

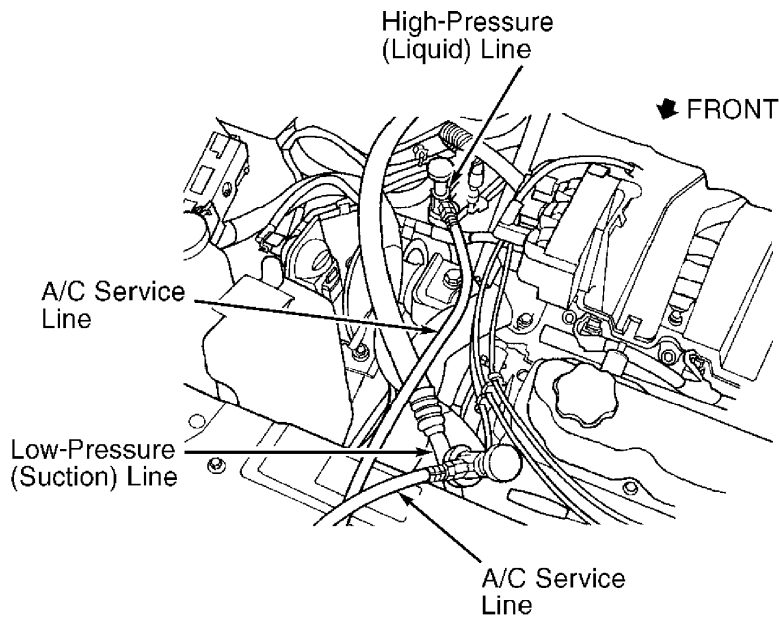

98J04007

Fig. 7: Locating Service Valves (Caravan, Town & Country, & Voyager)
Courtesy of DaimlerChrysler Corp.

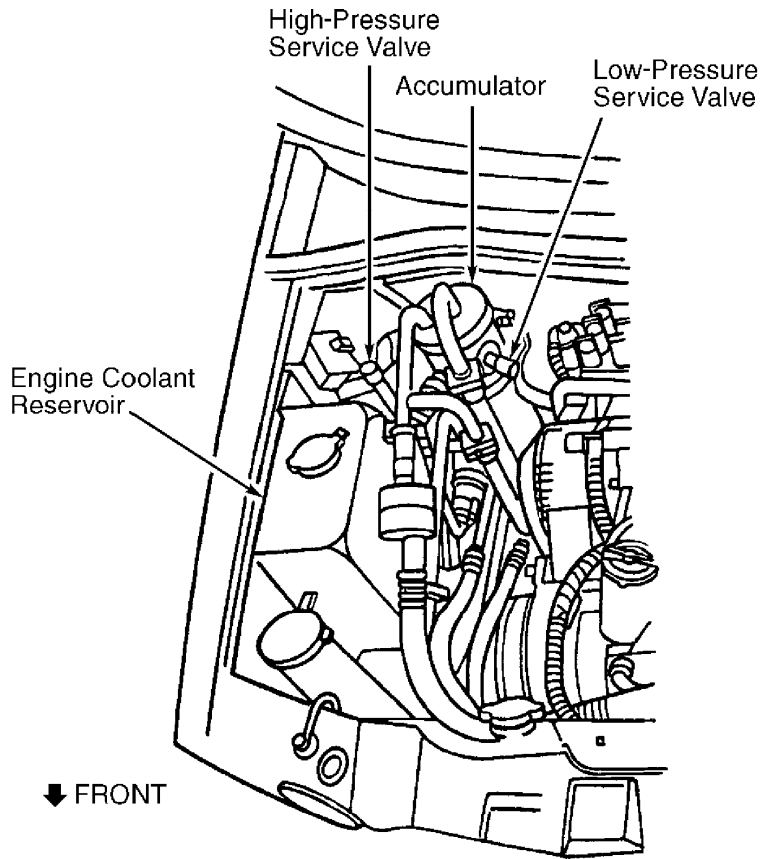

98B04008

Fig. 8: Locating Service Valves (Windstar)
Courtesy of Ford Motor Co.

SERVICE EQUIPMENT

Because R-134a is not interchangeable with R-12, separate sets of hoses, gauges, and recovery/recycling equipment are required to service vehicles. This is necessary to avoid cross-contamination and damaging system.

All equipment used to service systems using R-134a must meet SAE standard J2210. The service hoses on the manifold gauge set must have manual (turn wheel) or automatic back-flow valves at the service port connector ends. This will prevent refrigerant from being released into the atmosphere.

For identification purposes, R-134a service hoses must have a Black stripe along their length and be clearly labeled SAE J2196/134a. The low pressure test hose is Blue, with a Black stripe. The high-side test hose is Red, with a Black stripe. The center test hose is Yellow, or White, with a Black stripe.

NOTE: Refrigerant R-12 service hoses will only be labeled SAE J2196.

All R-134a manifold gauge sets can be identified by one or all of the following:

- * Labeled FOR USE WITH R-134a on set.
- * Labeled HFC-134 or R-134a on gauge face.
- * Light Blue color on gauge face. In addition, pressure/temperature scales on R-134a gauge sets are different from R-12 manifold gauge sets.

MANIFOLD GAUGE SET

A manifold gauge set is used to determine the system's high-side and low-side pressures, correct refrigerant charge, and operating efficiency. High (discharge) and low (suction) pressures must be compared to determine system operation. Manifold gauge sets for the 2 refrigerant types are basically the same except for fittings at ends of hoses. Fittings are different to ensure connection only to appropriate refrigerant system.

Service hoses on gauge set should have a manual turn wheel or automatic back-flow valves at service port connector ends. This will prevent refrigerant from being released into the atmosphere.

Low-Side Gauge & Hose - Low-side gauge, which may have a Blue identifying feature, is used to measure low-side (suction) pressure. Low-side gauge is also called a compound gauge because it can measure pressure and vacuum. Pressure scale ranges from 0 to 150 psi; vacuum scale ranges from 0 to 30 in. Hg. Low-side hose is Blue, with a Black stripe.

High-Side Gauge & Hose - High-side gauge, which may have a Red identifying feature, is used to measure high-side (discharge) pressure. Gauge scale ranges from 0 to 500 psi. High-side hose is Red, with a Black stripe.

Center Manifold Hose - Center manifold hose is either Yellow or White with a Black stripe. Center hose is used to recover, evacuate and charge refrigerant system. When low-side or high-side pressure valves are opened, refrigerant will escape through the charge hose.

CONNECTING GAUGE SET

NOTE: R-134a quick disconnect service couplings are connected in the same sequence as Schrader-type service valves.

Schrader-Type Valves

1) Put on safety goggles, and cover vehicle's fender. Slowly remove protective caps from Schrader valves to check for leaky valves.

CAUTION: Ensure hand valves on manifold gauge set and the hose-end shutoff valves are closed before attaching test hoses to Schrader valves.

2) Ensure service hoses are equipped with valve core depressor to match Schrader valve. If not, install special adapters for this purpose. If the high-side service hose connector will not fit

A/C SYSTEM GENERAL SERVICING

ABC123

Entire Article
2000 Chevrolet Camaro

on high-side Schrader valve, a special adapter must be used. See SPECIAL VALVE CONNECTORS.

3) Ensure both manifold gauge set hand valves are closed. Connect low-side service hose to low-side (suction) service valve, and finger-tighten connections. Connect high-side service hose to high-side (discharge) service valve, and finger-tighten connections.

NOTE: After test gauges are installed, test hoses must be purged of all air before proceeding with testing.

STABILIZING A/C SYSTEM

1) Once manifold gauge set is attached to system and test hoses have been purged, the system is ready for testing. Place all test hoses, gauge set and other equipment away from all moving parts of engine.

2) Start engine, and turn A/C controls to maximum cooling position (full cold or MAX A/C). Set blower on high speed. Open doors and/or windows. Operate system for 5-10 minutes. System should now be stabilized and ready for test readings.

PRESSURE-TEMPERATURE RELATIONSHIP

A refrigerant, when confined in an enclosed space, increases in pressure as the temperature increases. Conversely, if the temperature is lowered, the pressure also decreases.

Depending on temperature, a corresponding pressure will exist in such an enclosed space. For example, at 70°F (21.1°C) a gauge will indicate about 71.0 psi (5.0 kg/cm²). The R-134a PRESSURE-TEMPERATURE RELATIONSHIP table shows this relationship.

R-134a PRESSURE-TEMPERATURE RELATIONSHIP

AA
Temperature - °F (°C) (1) psi (kg/cm²)

20 (-6.7)	18 (1.3)
30 (-1.1)	26 (1.8)
40 (4.4)	35 (2.5)
50 (10.0)	45 (3.2)
60 (15.6)	57 (4.0)
70 (21.1)	71 (5.0)
80 (26.7)	87 (6.1)
90 (32.2)	104 (7.3)
100 (37.8)	124 (8.7)
110 (43.3)	147 (10.3)
120 (48.9)	171 (12.0)
130 (54.4)	199 (14.0)
140 (60.0)	229 (16.1)
150 (65.6)	263 (18.5)
160 (71.1)	300 (21.1)

(1) - Pressure readings are provided as a general guideline and may not represent actual readings.

AA

PRESSURE GAUGE READINGS

The pressure gauge readings shown represent an expansion valve type system using a Nippondenso 10-cylinder compressor. See Figs. 9 - 17. Gauge indications will vary depending on system configuration and compressor application.

Temperature and humidity, as well as other factors, affect pressure gauge readings. Compared to R-12 systems, pressure readings on R-134a systems are generally lower for low-side pressure and higher for high-side pressure. Pressure gauge readings should be used only as a guide.

NOTE: For additional information, see the latest MITCHELL(R) AUTOMOTIVE AIR CONDITIONING BASIC SERVICE TRAINING MANUAL.

NORMALLY FUNCTIONING A/C SYSTEM

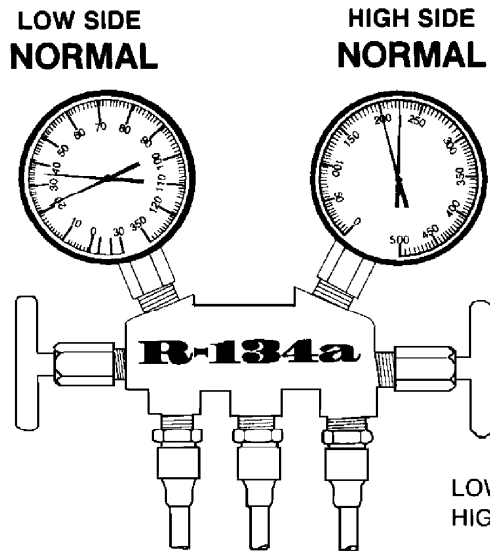

LOW SIDE - 29 psi (2.0 bar /2.0 kg/cm²)
HIGH SIDE - 215 psi (14.8 bar /15.1 kg/cm²)

- GAUGE READINGS** **Low Side Gauge** - Normal
- High Side Gauge** - Normal
- OTHER SYMPTOMS** **Sight Glass** - Clear.
- Discharge Air** - Cold.

95E17644

Fig. 9: Normally Functioning R-134a A/C System

SOME MOISTURE IN SYSTEM

LOW SIDE NORMAL-TO-LOW **HIGH SIDE NORMAL-TO-HIGH**

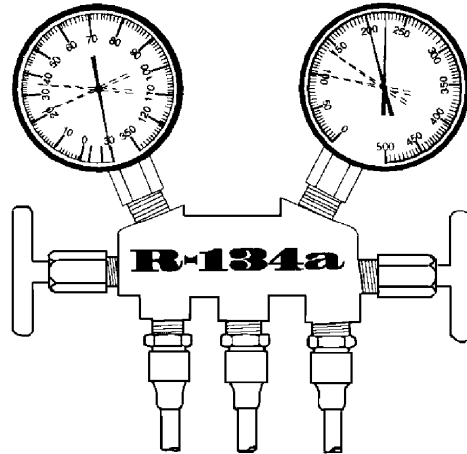

LOW SIDE - 30 psi (-2.1 bar /-2.1 kg/cm²)
HIGH SIDE - 214 psi (14.8 bar /15.0 kg/cm²)

GAUGE READINGS

Low Side Gauge - Normal, then sometimes drops to below zero

High Side Gauge - Normal, then sometimes goes high

DIAGNOSIS

Moisture In System Freezes Temporarily Stopping Cycle, However Normal System Operation Returns When Ice Melts.

CORRECTION

- 1) Evacuate A/C system.
- 2) Replace receiver-drier.
- 3) Remove moisture by repeatedly evacuating system.
- 4) Charge system with R-134a.
- 5) Operate system and check performance.

95F17645

Fig. 10: Some Moisture In R-134a System

LOW R-134a CHARGE

LOW SIDE LOW **HIGH SIDE LOW**

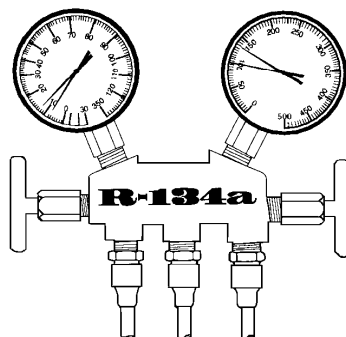

LOW SIDE - 11 psi (.76 bar / .77 kg/cm²)
HIGH SIDE - 121 psi (8.3 bar /8.5 kg/cm²)

GAUGE READINGS

Low Side Gauge - Low

High Side Gauge - Low

OTHER SYMPTOMS

Sight Glass - Bubbles continuously visible.

DIAGNOSIS

System Slightly Low On R-134a Due To Leak Or Incorrect Charge.

CORRECTION

- 1) Leak test system.
- 2) Evacuate A/C system.
- 3) Repair system leaks.
- 4) Charge system with R-134a.
- 5) Operate system and check performance.

95G17646

Fig. 11: Low R-134a Charge

POOR REFRIGERANT CIRCULATION

**LOW SIDE
ZERO-TO-NEGATIVE**

**HIGH SIDE
LOW**

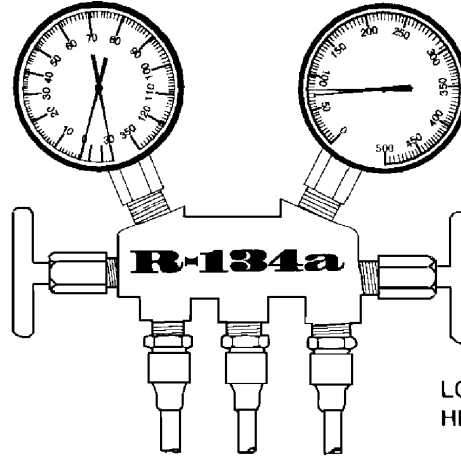

LOW SIDE - -15 psi (-1.0 bar /-1.1 kg/cm²)
HIGH SIDE - 78 psi (5.4 bar /5.5 kg/cm²)

GAUGE READINGS

Low Side Gauge - Zero-to-negative

High Side Gauge - Low

OTHER SYMPTOMS

Receiver-Drier - Frost on tubes from receiver-drier to evaporator unit.

DIAGNOSIS

Refrigerant Flow Obstructed By Dirt, Receiver-Drier Clogged.

CORRECTION

- 1) Evacuate A/C system.
- 2) Replace receiver-drier.
- 3) Charge system with R-134a.
- 4) Operate system and check performance.

95H17647

Fig. 12: Poor R-134a Refrigerant Circulation

NO REFRIGERANT CIRCULATION

**LOW SIDE
ZERO-TO-NEGATIVE**

**HIGH SIDE
LOW**

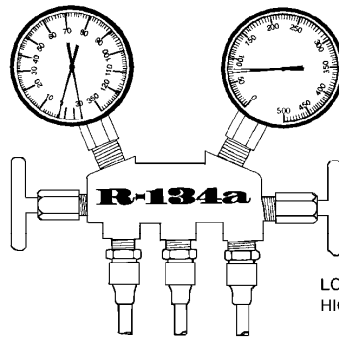

LOW SIDE - -15 psi (-1.0 bar /-1.1 kg/cm²)
HIGH SIDE - 78 psi (5.4 bar /5.5 kg/cm²)

GAUGE READINGS

Low Side Gauge - Zero-to-negative

High Side Gauge - Low

OTHER SYMPTOMS

Receiver-Drier - Frost or moisture on tubes before and after receiver-drier.

DIAGNOSIS

Refrigerant Flow Obstructed By Dirt Or Moisture Or Refrigerant Flow Obstructed By Gas Leakage From Expansion Valve Heat Sensing Tube.

CORRECTION

- 1) Evacuate A/C system.
- 2) Check heat sensing tube at expansion valve. Replace expansion valve if necessary.
- 3) Remove expansion valve and attempt removal of dirt. If dirt cannot be removed, replace expansion valve.
- 4) Replace receiver-drier.
- 5) Charge system with R-134a.
- 6) Operate system and check performance.

95I17648

Fig. 13: No R-134a Refrigerant Circulation

ABC123

Entire Article
2000 Chevrolet Camaro

**INSUFFICIENT COOLING OF CONDENSER
OR REFRIGERANT OVERCHARGE**

LOW SIDE
HIGH

HIGH SIDE
HIGH

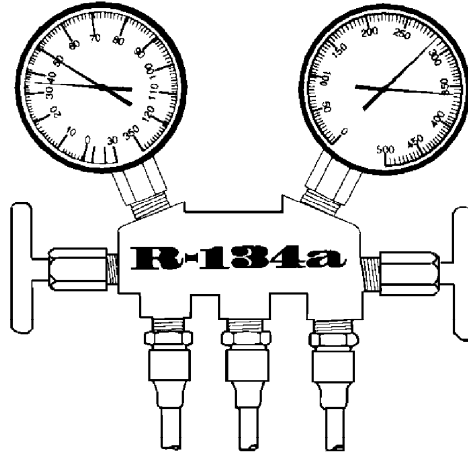

LOW SIDE - 43 psi (3.0 bar /3.0 kg/cm²)
HIGH SIDE - 320 psi (22.1 bar /22.5 kg/cm²)

GAUGE READINGS

Low Side Gauge - High

OTHER SYMPTOMS

High Side Gauge - High

DIAGNOSIS

Sight Glass - No bubbles visible even after lowering engine RPM.

CORRECTION

Refrigerant Overcharge, Condenser Cooling Fins Clogged With Dirt Or Cooling Fans Malfunctioning.

- 1) Clean condenser cooling fins.
- 2) Check cooling fan operation.
- 3) Evacuate A/C system.
- 4) Charge system with R-134a.
- 5) Operate system and check performance.

95.J17649

Fig. 14: Insufficient Cooling Of Condenser Or R-134a Refrigerant Overcharge

ABC123

Entire Article
2000 Chevrolet Camaro

AIR IN SYSTEM

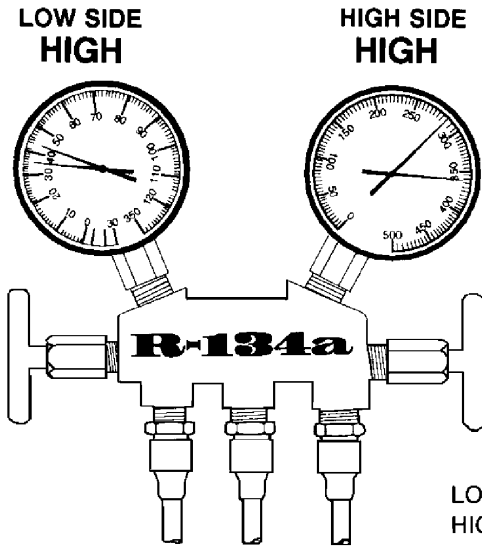

LOW SIDE – 40 psi (2.8 bar /2.8 kg/cm²)
HIGH SIDE – 320 psi (22.1 bar /22.5 kg/cm²)

GAUGE READINGS

OTHER SYMPTOMS

DIAGNOSIS

CORRECTION

Low Side Gauge – High

High Side Gauge – High

Sight Glass – Bubbles visible during system operation.

Pipes – Low pressure pipes are hot to the touch.

Air Is Present In System Possibly From Inadequate Evacuation Procedure.

- 1) Evacuate A/C system.
- 2) Check compressor oil for contamination. Check compressor for proper oil amount. Correct if necessary.
- 3) Charge system with R-134a.
- 4) Operate system and check performance.

95D17650

Fig. 15: Air In R-134a System

**EXPANSION VALVE IMPROPERLY MOUNTED
OR HEAT SENSING TUBE DEFECTIVE (OPENING TOO WIDE)**

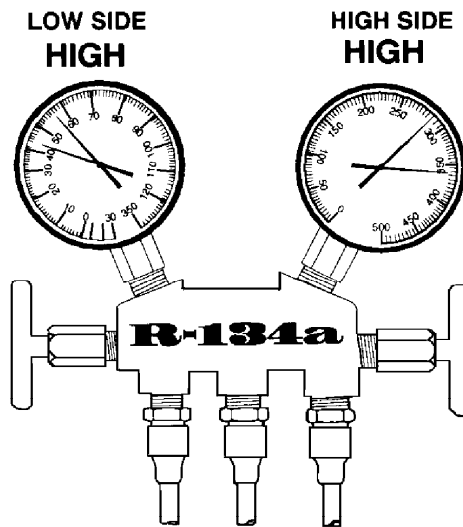

LOW SIDE - 50 psi (3.5 bar /3.5 kg/cm²)
HIGH SIDE - 320 psi (22.1 bar /22.5 kg/cm²)

- | | |
|-----------------------|--|
| GAUGE READINGS | Low Side Gauge - High |
| | High Side Gauge - High |
| OTHER SYMPTOMS | Pipes - Large amount of frost or moisture on low side pipes. |
| DIAGNOSIS | Excessive Refrigerant In Low Side Pipes Possibly From Expansion Valve Being Opened Too Wide. |
| CORRECTION | <ol style="list-style-type: none"> 1) Check heat sensing tube for proper installation. 2) If heat sensing tube is properly positioned, evacuate A/C system. 3) Check expansion valve and replace if defective. 4) Charge system with R-134a. 5) Operate system and check performance. |

95E17651

Fig. 16: Expansion Valve Improperly Mounted Or Heat Sensing Tube Defective (Opening Too Wide)

COMPRESSOR MALFUNCTION

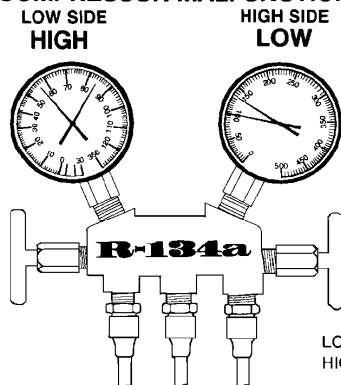

LOW SIDE - 71 psi (4.9 bar /5.0 kg/cm²)
HIGH SIDE - 121 psi (8.3 bar /8.5 kg/cm²)

- | | |
|-----------------------|--|
| GAUGE READINGS | Low Side Gauge - High |
| | High Side Gauge - Low |
| DIAGNOSIS | Internal Compressor Leak Or Compressor Mechanically Broken. |
| CORRECTION | <ol style="list-style-type: none"> 1) Evacuate A/C system. 2) Repair or replace compressor. 3) Charge system with R-134a. 4) Operate system and check performance. |

95F17652

Fig. 17: Compressor Malfunction

ORIFICE TUBE REPLACEMENT**DAIMLERCHRYSLER CORP.**

Removal & Installation (Dakota)

1) Disconnect negative battery cable. Discharge A/C system, using approved refrigerant recovery/recycling equipment. Disconnect liquid line at condenser outlet tube. Cover open refrigerant fittings to protect from moisture and dirt.

2) Using 2 wrenches, loosen tube fitting and separate front half of liquid line from rear half of liquid line. Using needle nose pliers, remove fixed orifice tube from rear half of liquid line. Note fixed orifice tube orientation for correct installation.

3) To install, reverse removal procedure. Using 2 wrenches, tighten liquid line outlet tube fittings to 14-19 ft. lbs. (19-26 N. m). Ensure fixed orifice tube is positioned correctly. Evacuate, charge, and leak test A/C system. Ensure A/C system operates properly.

NOTE: On Ram Pickup, if fixed orifice tube is faulty or plugged, liquid line and orifice tube must be replaced as an assembly.

Removal & Installation (Ram Pickup)

Disconnect negative battery cable. Discharge A/C system, using approved refrigerant recovery/recycling equipment. Disconnect liquid line from evaporator inlet and condenser outlet tubes. Cover open refrigerant fittings to protect from moisture and dirt. Disconnect liquid line retaining clips. Remove liquid line and orifice tube. To install, reverse removal procedure. Evacuate, charge, and leak test A/C system. Ensure A/C system operates properly.

FORD MOTOR CO.

NOTE: Replace orifice tube whenever compressor is replaced. Fixed orifice tube is located in rear condenser-to-evaporator liquid line.

NOTE: DO NOT use pliers to remove fixed orifice tube or twist orifice tube in liquid line. Doing so will cause plastic orifice tube body to break inside condenser-to-evaporator liquid line.

NOTE: On Mustang, replacement of fixed orifice tube requires replacement of rear condenser-to-evaporator line and orifice tube assembly.

Fixed Orifice Tube Replacement (Except Continental)

1) Disconnect negative battery cable. Discharge A/C system, using approved refrigerant recovery/recycling equipment. On Contour and Mystique, move power steering fluid reservoir to one side without disconnecting hoses.

2) On all models, disconnect condenser-to-evaporator discharge (liquid) line. Plug refrigerant lines to prevent contamination. Remove and discard "O" rings from line. Pour a small amount of refrigerant oil into inlet to lubricate old orifice "O"

rings.

3) Insert Fixed Orifice Tube Remover/Installer (T83L-19990-A) into tube and turn tool to right to engage tangs on orifice tube. See Fig. 18. Hold remover/installer "T" handle and slowly rotate body to slowly pull orifice tube out.

4) If orifice tube breaks off when removal is attempted, use Broken Orifice Tube Extractor (T83L-19990-A) to remove broken section. See Fig. 19.

5) Lubricate replacement orifice tube "O" ring(s) with clean refrigerant oil. Place orifice tube into remover/installer. Insert tube, with short end toward evaporator, until seated. Reconnect high pressure line. On Contour and Mystique, tighten connection to 18 ft. lbs. (24 N.m).

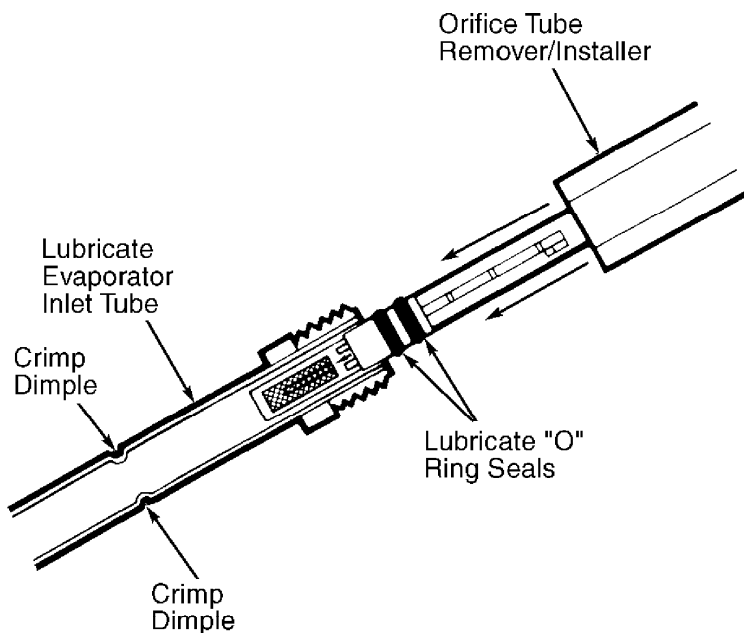

95G60000

Fig. 18: Removing Orifice Tube (Typical)
Courtesy of Ford Motor Co.

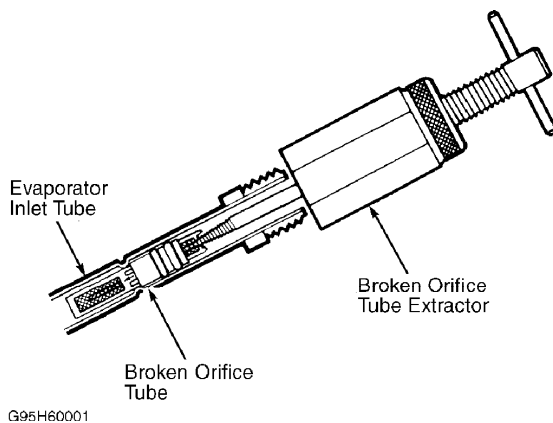

G95H60001

Fig. 19: Removing Broken Orifice Tube (Typical)
Courtesy of Ford Motor Co.

NOTE: On Continental, if orifice tube is faulty or plugged, liquid line and orifice tube must be replaced as an assembly or an orifice tube replacement kit must be installed.

Orifice Tube Replacement Kit (Continental)

1) Discharge A/C system, using approved refrigerant recovery/recycling equipment. Remove condenser-to-evaporator liquid line from vehicle. Locate orifice tube in metal portion of liquid line, near bend (indented notches or circular depression). See Fig. 20

2) Cut a 2.5" (63.5 mm) section from liquid line, at least 1" (25.4 mm) from start of bend in line, and discard. Clean out liquid line to remove contaminants.

3) Lubricate orifice tube replacement kit compression nuts and rings with refrigerant oil and install on liquid line. See Fig. 21. Ensure flow direction arrow points toward evaporator. Ensure liquid line is properly aligned for installation. Tighten compression nuts to 65-69 ft. lbs. (88-94 N.m).

4) To complete installation, reverse removal procedure. Lubricate "O" rings with refrigerant oil. Evacuate, charge and leak test system. Ensure A/C system is operating properly.

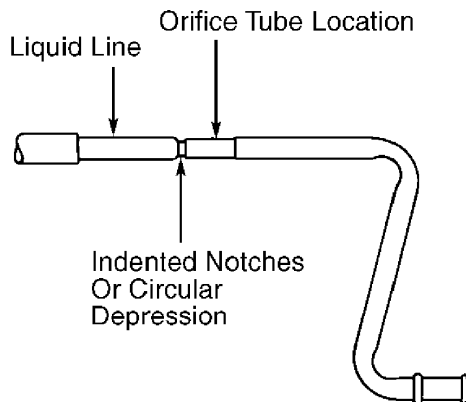

90J02503

Fig. 20: Locating Orifice Tube (Continental)
Courtesy of Ford Motor Co.

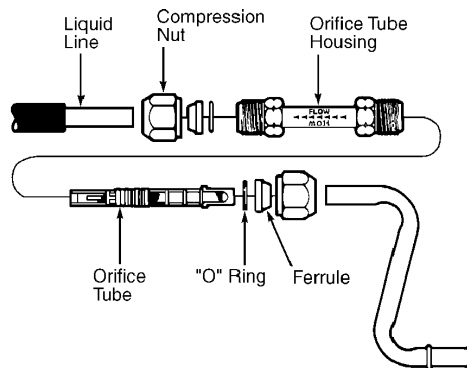

95160002

Fig. 21: Installing Orifice Tube Kit (Continental)
Courtesy of Ford Motor Co.

GENERAL MOTORS

Removal ("C", "E", "K" & "H" Body)

1) Locate orifice tube. See

ORIFICE TUBE LOCATION & REMOVER/INSTALLER APPLICATION (GENERAL MOTORS) table. Discharge A/C system, using approved recovery/recycling equipment. Disconnect liquid line retaining clips.

2) Disconnect liquid line, at orifice tube location, between evaporator and condenser. Use Dual "O" Ring Joint Separator (J-38042) to hold pressure against liquid line female nut while loosening nut, if necessary. Remove and discard liquid line "O" rings using a nonmetallic tool so seal surface is not damaged.

3) Remove orifice tube using specified orifice tube remover.

See

ORIFICE TUBE LOCATION & REMOVER/INSTALLER APPLICATION (GENERAL MOTORS) table.

Installation

1) Install liquid line "O" rings. Lubricate inside of evaporator inlet line and "O" rings with refrigerant oil. Lubricate orifice tube and "O" ring with refrigerant oil. Insert orifice tube into evaporator inlet line, with short screen toward condenser.

2) Tighten liquid line nut to 18 ft. lbs. (24 N.m). To complete installation, reverse removal procedure. Evacuate, charge, and test system for proper operation.

Removal ("F" Body)

Discharge A/C system, using approved recovery/recycling equipment. Disconnect negative battery cable. Disconnect A/C pressure switch connector. Use a back-up wrench to hold evaporator fitting, and loosen evaporator liquid line fitting. Remove bolt. Disconnect evaporator liquid line. Remove and discard "O" rings. Using needle-nose pliers, remove orifice tube from evaporator inlet line.

Installation

1) Clean evaporator line fitting with refrigerant oil. Coat inside of inlet line and evaporator line "O" rings with refrigerant oil. Lubricate orifice tube and "O" ring with refrigerant oil, and insert "O" rings into inlet line. Insert orifice tube into evaporator inlet line, with long screen inlet end toward condenser.

2) Tighten bolt to 12 ft. lbs. (16 N.m). Tighten evaporator line fitting to 28 ft. lbs. (38 N.m). To complete installation, reverse removal procedure. Evacuate, charge, and test system for proper operation.

Removal ("J" & "N" Body)

1) Locate orifice tube. See

ORIFICE TUBE LOCATION & REMOVER/INSTALLER APPLICATION (GENERAL MOTORS) table. Discharge A/C system, using approved recovery/recycling equipment. On "J" body, remove upper closeout panel. On "N" body, raise and support vehicle. On all models, disconnect condenser-to-evaporator line at condenser outlet and discard "O" rings.

2) Disconnect condenser-to-evaporator line clip on right-side

A/C SYSTEM GENERAL SERVICING

ABC123

Entire Article
2000 Chevrolet Camaro

body rail, behind engine mount. Remove as much impacted debris as possible. Grip orifice tube using needle-nose pliers. Using a turning and push-pull motion, remove orifice tube.

3) If difficulty is encountered during removal of a plugged or restricted orifice tube, apply heat to orifice tube using a heat gun. Carefully apply heat 1/4" (7 mm) from dimples on condenser inlet line. DO NOT overheat line.

4) If A/C pressure switch is located near orifice tube, remove switch to protect from heat. While heat is being applied, grip orifice tube using orifice tube remover/installer or needle-nose pliers. Use a turning motion along with a push-pull motion to loosen and remove orifice tube.

Installation

1) Coat inside of condenser inlet line and "O" rings with refrigerant oil. Lubricate orifice tube "O" ring with refrigerant oil, and insert into condenser inlet line. Insert orifice tube into condenser inlet line, with shorter screen toward evaporator.

2) Connect condenser-to-evaporator line clip on right side body rail. Lubricate "O" rings and connect condenser inlet line. On "J" body, tighten condenser inlet line nut to 12 ft. lbs. (16 N.m). On "N" body, tighten condenser inlet line bolt to 18 ft. lbs. (24 N.m). On all models, install closeout panel. Evacuate, charge, and test system for proper operation.

Removal ("W" Body)

1) Locate orifice tube. See ORIFICE TUBE LOCATION & REMOVER/INSTALLER APPLICATION (GENERAL MOTORS) table. Remove air cleaner and duct assembly. Discharge A/C system, using approved recovery/recycling equipment. Disconnect negative battery cable. Disconnect ABS modulator and A/C pressure sensor/fan switch electrical connectors.

2) Disconnect liquid line/suction line bracket. Disconnect liquid line at orifice tube. Remove orifice tube using specified orifice tube remover/installer. See ORIFICE TUBE LOCATION & REMOVER/INSTALLER APPLICATION (GENERAL MOTORS) table.

3) If difficulty is encountered during removal of a plugged or restricted orifice tube, remove as much residue as possible. Using a heat gun, carefully heat inlet line. If inlet line has small dimples, apply heat 1/4" from dimples. DO NOT overheat line.

4) If A/C pressure switch is located near orifice tube, remove switch to protect from heat. While heat is being applied, grip orifice tube using needle-nose pliers. Use a turning motion along with a push-pull motion to loosen and remove orifice tube.

Installation

1) Coat inside of inlet line and "O" ring with refrigerant oil. Lubricate orifice tube and "O" ring with refrigerant oil, and insert "O" rings into inlet line. Insert orifice tube into evaporator inlet line, with short screen toward condenser.

2) Tighten liquid line fitting at orifice tube to 20 ft. lbs. (27 N.m). To complete installation, reverse removal procedure. Evacuate, charge, and test system for proper operation.

Removal ("C" & "K" Series)

1) Discharge A/C system, using approved recovery/recycling equipment. On models equipped with front A/C system only, remove front grille. Using a back-up wrench, loosen condenser-to-evaporator (liquid) line fitting at condenser and disconnect line.

2) On models equipped with rear A/C system, loosen condenser-to-evaporator (liquid) line fitting between junction block and evaporator. If necessary, remove air cleaner assembly.

3) On all models, remove and discard fitting "O" ring. Using Orifice Tube Remover/Installer (J-26549-E), remove orifice tube from liquid line. If difficulty is encountered during removal of a plugged or restricted orifice tube, remove as much residue as possible.

4) Using a heat gun, carefully apply heat 1/4" from dimples on liquid line. DO NOT overheat line. If A/C pressure switch is located near orifice tube, remove switch to protect from heat.

5) While heat is being applied, grip orifice tube using orifice tube remover/installer. Use a turning motion along with a push-pull motion to loosen and remove orifice tube.

Installation

1) Clean liquid line fitting with refrigerant oil. Coat inside of liquid line and "O" ring with refrigerant oil. Lubricate orifice tube and "O" ring with refrigerant oil, and insert "O" rings into liquid line. Insert longer orifice tube screen (inlet end) into condenser outlet line first, toward condenser.

2) Tighten liquid line fitting to 18 ft. lbs. (24 N.m). To complete installation, reverse removal procedure. Evacuate, charge, and test system for proper operation.

Removal ("G", "L" & "M" Series)

1) Discharge A/C system, using approved recovery/recycling equipment. Using a back-up wrench, loosen evaporator inlet (liquid) line fitting at evaporator. Disconnect inlet line. Remove and discard "O" ring(s). Using Orifice Tube Remover/Installer (J-26549-E), remove orifice tube from liquid line.

2) If difficulty is encountered during removal of a plugged or restricted orifice tube, remove as much residue as possible. Using a heat gun, carefully apply heat 1/4" from dimples on liquid line. DO NOT overheat line.

3) If A/C pressure switch is located near orifice tube, remove switch to protect from heat. While heat is being applied, grip orifice tube using orifice tube remover/installer. Use a turning motion along with a push-pull motion to loosen and remove orifice tube.

Installation

1) Clean liquid line fitting with refrigerant oil. Add one ounce of refrigerant oil to system. Coat inside of liquid line and "O" rings with refrigerant oil. Lubricate orifice tube and "O" ring with refrigerant oil, and insert "O" rings into liquid line. Insert shorter orifice tube screen into liquid line first, with long screen (inlet end) toward condenser.

2) Tighten liquid line fitting to 20 ft. lbs. (27 N.m). To

A/C SYSTEM GENERAL SERVICING

ABC123

Entire Article
2000 Chevrolet Camaro

complete installation, reverse removal procedure. Evacuate, charge, and test system for proper operation.

Removal ("U" Series)

1) Remove air cleaner and duct assembly. Discharge A/C system, using approved recovery/recycling equipment. Using a back-up wrench, loosen condenser outlet (liquid) line fitting at orifice tube. Disconnect liquid line. Remove and discard "O" rings. Using needle-nose pliers, remove orifice tube from liquid line.

2) If difficulty is encountered during removal of a plugged or restricted orifice tube, remove as much residue as possible. Using a heat gun, carefully apply heat 1/4" from dimples on liquid line. DO NOT overheat line.

3) If A/C pressure switch is located near orifice tube, remove switch to protect from heat. While heat is being applied, grip orifice tube using needle-nose pliers. Use a turning motion along with a push-pull motion to loosen and remove orifice tube.

Installation

1) Clean liquid line fitting with refrigerant oil. Add one ounce of refrigerant oil to system. Coat inside of liquid line and "O" rings with refrigerant oil. Lubricate orifice tube and "O" ring with refrigerant oil, and insert "O" rings into liquid line. Insert orifice tube into liquid line, with long screen (inlet end) toward condenser.

2) Tighten liquid line fitting to 20 ft. lbs. (27 N.m). To complete installation, reverse removal procedure. Evacuate, charge, and test system for proper operation.

ORIFICE TUBE LOCATION & REMOVER/INSTALLER APPLICATION (GENERAL MOTORS)
 AA

	Ori fi ce Tube		Ori fi ce Tube Remover/ Instal ler
Appl i cati on	Locati on		

Cars

"C" Body (1) (2)
"E" & "K" Body (1)	J-26549-D
"F" Body Evaporator Inlet (2)
"G" Body Evaporator Inlet	J-26549-E
"H" Body Condenser Outlet	J-26549-D
"J" & "N" Body Condenser Outlet (3)
"W" Body (4)	J-26549-E

Trucks & Vans

"C" & "K" Series		
With Rear A/C	... Evaporator Inlet	J-26549-E
Without Rear A/C	... Condenser Outlet	J-26549-E
"G" Series Evaporator Inlet	J-26549-E
"L" & "M" Series	... Evaporator Inlet	J-26549-E
"S" & "T" Series	... Evaporator Inlet	J-26549-D
"U" Series Condenser Outlet (2)

- (1) - In evaporator (liquid) inlet line, between service valves, above accumulator.
- (2) - Grip orifice tube using orifice tube needle-nose pliers. Use a turning motion along with a push-pull motion to loosen

ABC123

Entire Article
2000 Chevrolet Camaro

and remove orifice tube.

- (3) - When replacing orifice tube, compare original orifice tube design with replacement component to ensure correct selection.
- (4) - In evaporator (liquid) inlet line, between high-side service valve and evaporator.

AA

JEEP

NOTE: On Cherokee, Grand Cherokee and Wrangler, fixed orifice tube is located in liquid line. If fixed orifice tube is faulty or plugged, liquid line and orifice tube must be replaced as an assembly.

Removal & Installation

Disconnect battery negative cable. Discharge A/C system, using approved refrigerant recovery/recycling equipment. Disconnect liquid line retaining clips. Disconnect liquid line from evaporator inlet and condenser outlet tubes. Cover open refrigerant fittings to protect from moisture and dirt. Remove liquid line and orifice tube. To install, reverse removal procedure. Evacuate, charge, and leak test A/C system. Ensure A/C system operates properly.

REFRIGERANT RECOVERY/RECYCLING

Refrigerant recovery/recycling equipment is used to remove refrigerant from vehicle's A/C system without polluting atmosphere. To remove and recycle refrigerant, always follow instructions provided with refrigerant recovery/recycling equipment being used.

Removed refrigerant is filtered, dried and stored in a tank within recovery/recycling equipment until it is ready to be pumped back into vehicle's A/C system.

NOTE: Separate sets of hoses, manifold gauge set and refrigerant recovery/recycling equipment must be used for R-12 and R-134a systems. DO NOT mix R-12 and R-134a refrigerants, as their refrigerant oils and desiccants are not compatible.

DAIMLERCHRYSLER CORP.

Manufacturer recommends using refrigerant recovery/recycling equipment which meets SAE standard J2210. Always follow instructions provided with the recovery/recycling equipment being used.

FORD MOTOR CO.

- 1) Connect hoses from Recovery/Recycling/Charging Center (023-00150) to high-side and low-side service valves. See SYSTEM SERVICE VALVES under SYSTEM SERVICE VALVES.
- 2) Turn equipment on and recover refrigerant according to equipment manufacturer's operating instructions. Allow equipment to operate until refrigerant is recovered. Close inlet valve (if equipped) on refrigerant recovery/recycling/charging center and turn

equipment off.

NOTE: On some applications, refrigerant recovery/recycling/charging center will automatically shut off through use of a low pressure switch. On other applications, refrigerant recovery/recycling/charging center must be manually shut off.

3) Allow A/C system to remain closed for about 2 minutes while observing vacuum pressure readings. If vacuum pressure reading increases, repeat step 2) until vacuum pressure readings remain stable for 2 minutes. If vacuum pressure readings remain stable for 2 minutes, disconnect hoses from service ports and perform required A/C system repairs.

GENERAL MOTORS

Manufacturer recommends using A/C Refrigerant Recovery, Recycling & Recharging (ACR4) System (J-39500). ACR4 system has one filtering cycle during recovery plus an automatic multiple-pass filtering during evacuation cycle. Follow manufacturer's instructions provided with ACR4 equipment being used.

JEEP

Manufacturer recommends using refrigerant recovery/recycling equipment which meets SAE standard J1991 or J2210. Always follow instructions provided with recovery/recycling equipment being used.

FLUSHING A/C SYSTEM

There is considerable controversy over the question of whether or not to flush A/C systems or how to go about it. Before CFCs were classified as harmful to the environment, it was a common practice to open flush contaminants from a system. The waste fluid was vented to the atmosphere. This practice is now illegal and can no longer be used.

Most OEMs don't recommend A/C system flushing. They recommend replacing the defective component and installing a liquid line (in-line) filter ahead of the expansion valve or orifice tube. Ford Motor Company is one exception to this rule.

DAIMLERCHRYSLER CORP.

Information is not available from manufacturer.

FORD MOTOR CO.

NOTE: DO NOT flush accumulator/receiver-drier, muffler, hoses and thermal expansion valve/fix ed orifice tube, as residual flushing agent cannot be completely removed from these components. These components are generally replaced after A/C system contamination. Hoses can be reused, unless they are clogged with debris. Only flush evaporator core and condenser

core, and metal inlet and outlet lines. These components can be flushed while installed in vehicle.

A/C System Flushing

1) Manufacturer recommends flushing contaminated system using one gallon of Ford A/C System Flushing Solvent (F4AZ-19579-A), Filter (FL-1A), A/C Flusher Fitting Kit (014-00992 or 219-00024) and A/C Flush/Purge Machine (014-00991 or 219-00022). DO NOT reuse flushing solvent and filter, they are intended to be used on one vehicle only.

2) Discharge A/C system, using approved refrigerant recovery/recycling equipment. Disconnect refrigerant lines from heat exchanger (condenser or evaporator) to be flushed. Using flush and purge fitting kit, connect A/C flush and purge machine to heat exchanger according to manufacturer instructions.

3) Circulate flushing solvent through heat exchanger in reverse direction of normal refrigerant flow (back-flushing). Flush component for a least 15 minutes. Stop flow of solvent. To remove solvent from heat exchanger, apply 90-125 psi (6.3-8.8 kg/cm²) of compressed air to component for at least 30 minutes.

4) Compressed air is used to purge and evaporate all residual solvent from component. A/C system can be damaged if any solvent remains in system. Dispose of used flush solvent and filter in accordance with local, state and federal emissions statutes.

5) Using an A/C system filter is optional after system flushing is completed. However, if A/C system contamination is extensive, a filter kit is recommended after flushing. See A/C SYSTEM FILTERING.

6) After flushing is completed, install a NEW orifice tube if there has been a compressor failure or desiccant contamination. Install NEW refrigerant hoses if clogged with debris. Complete component installation, adding additional refrigerant oil as required. Evacuate, leak test and recharge A/C system and ensure proper operation.

A/C System Filtering

1) If an A/C system flusher is not available to clean A/C system, an in-line filter kit can be used. Filter kit is installed before replacement compressor, accumulator/receiver-drier, muffler, and thermal expansion valve/fixed orifice tube have been installed.

2) Filter kits are used with either a rubber lined suction hose or with a nylon lined suction hose located between compressor and evaporator. Rubber lined hose has a wall thickness of 1/4" and nylon lined hose has a wall thickness of 1/8". See Fig. 22.

3) Filter kit for either type hose has 2 filters. A temporary pancake filter and a permanent in-line suction filter. Pancake filter is temporarily installed between condenser and condenser-to-evaporator line. See Fig. 23. Permanent filter is installed in suction line between accumulator and compressor.

4) Install replacement components (compressor, accumulator and fixed orifice) with correct amount of refrigerant oil. See COMPRESSOR REFRIGERANT OIL CHECKING article.

5) Cut suction hose between compressor and accumulator (closer to compressor). Remove a length of suction hose to accommodate suction filter. Measure side wall of suction hose and install

appropriate filter with "O" rings and filter clamps. If side wall is 1/4", use in-line filter labeled USE WITH RUBBER INNER LINED HOSE. If side wall is 1/8", use in-line filter labeled USE WITH NYLON INNER LINED HOSE. Ensure arrow on filter is pointing in direction of refrigerant flow. Tighten hose clamps to 54 INCH lbs. (6 N.m). See Fig. 22.

6) Install pancake filter in liquid line between condenser and condenser-to-evaporator line. Ensure filter inlet (label) is toward condenser. Evacuate, charge, and leak test A/C system. See the following:

- * EVACUATING A/C SYSTEM
- * CHARGING A/C SYSTEM
- * LEAK TESTING

Check filters and hoses for clearance from other engine components. Use tie straps if necessary.

7) Place external cooling fan in front of radiator. Select MAX A/C operation and set blower motor speed to maximum. Start engine and allow to idle. Ensure A/C is operating properly. Slowly increase engine speed to 800 RPM, then 1000 RPM, and then to 1200 RPM. With engine speed set to 1200 RPM, operate engine for one hour with A/C system operating.

8) Stop engine. Discharge A/C system, using approved refrigerant recovery/recycling equipment. Remove pancake filter, hoses and fittings. Discard pancake filter. Reconnect liquid line, evacuate, charge, and leak test A/C system. Ensure A/C system is operating properly.

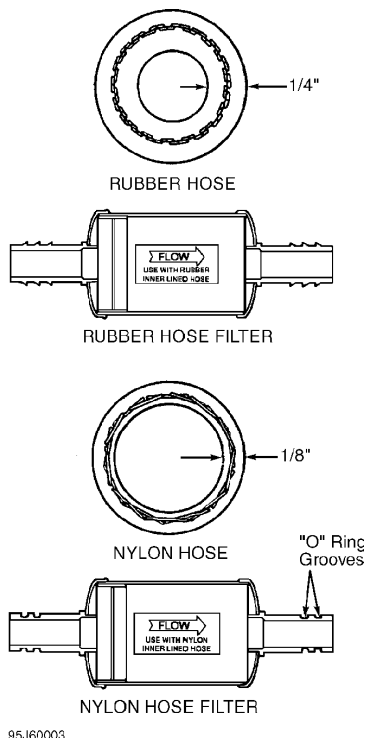
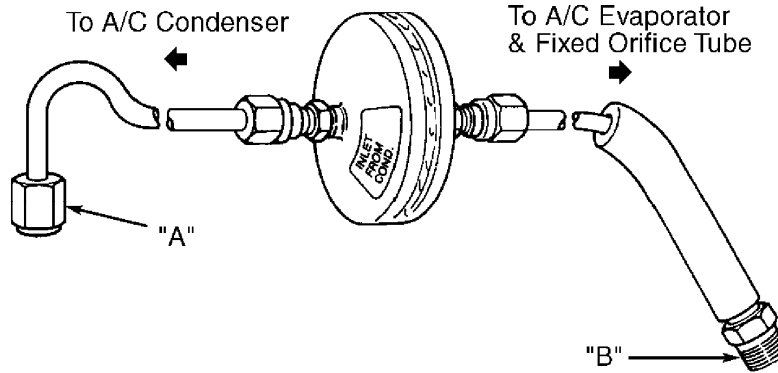

Fig. 22: Permanent A/C System Filters
Courtesy of Ford Motor Co.



95A60004

Fig. 23: Temporary Pancake Filter
Courtesy of Ford Motor Co.

GENERAL MOTORS

Information is not available from manufacturer.

JEEP

Information is not available from manufacturer.

EVACUATING A/C SYSTEM

CAUTION: DO NOT operate A/C compressor during evacuation procedure or with vacuum applied to A/C system. Compressor may be damaged.

DAIMLERCHRYSLER CORP.

Caravan, Neon, 2001 Sebring Sedan, 2001 Stratus Sedan, Sebring Convertible, Town & Country, & Voyager

1) Connect approved recovery/recycling equipment and manifold gauge set. Fully open manifold gauge set low-side and high-side valves, and start vacuum pump. Operate vacuum pump for 45 minutes after low-side vacuum reading is 26 in. Hg or more (28 in. Hg or more on Neon). Close all valves and turn vacuum pump off.

2) If A/C system fails to reach specified vacuum, or does not maintain specified vacuum for at least 30 minutes, check for a defective vacuum pump or leak in A/C system or gauge set. See LEAK TESTING. Perform repairs as necessary.

3) If A/C system maintains specified vacuum for at least 30 minutes, restart vacuum pump, open low-side and high-side valves, and evacuate system for an additional 10 minutes. Close all valves. Turn vacuum pump off and disconnect pump.

Cherokee, Dakota, Durango, Grand Cherokee, Ram Pickup, Ram Van/Wagon & Wrangler

1) Connect approved recovery/recycling equipment and manifold gauge set. Fully open manifold gauge set low-side and high-side valves, and start vacuum pump. Operate vacuum pump until low-side

vacuum reading of 26 in. Hg or more. Close all valves and turn vacuum pump off. Observe vacuum gauge and go to next step.

2) If A/C system maintains specified vacuum for 5 minutes, restart vacuum pump, open low-side and high-side valves, and evacuate system for an additional 10 minutes. Close all valves. Turn vacuum pump off and disconnect pump.

3) If A/C system cannot get to or maintain specified vacuum, check for a defective vacuum pump or a leak in A/C system or gauge set. See LEAK TESTING. Repair or replace components as necessary.

All Other Models

Connect approved recovery/recycling equipment to vehicle. Evacuate A/C system using recovery/recycling equipment according to manufacturer's instructions.

FORD MOTOR CO.

1) If using approved Recovery/Recycling/Charging Center (023-00150) connect to high-side and low-side service valves. See SYSTEM SERVICE VALVES under SYSTEM SERVICE VALVES. Connect manifold gauge set center hose to vacuum pump.

2) Open both valves on manifold gauge set. Operate vacuum pump until low-side vacuum reading is at least 29.5 in. Hg (as close to 30 in. Hg as possible). Operate vacuum pump for at least 45 minutes.

NOTE: If A/C system was open for an extended period (several hours), replace accumulator/receiver-drier and increase evacuation time to 2-3 hours.

3) Close both valves on manifold gauge set. Turn off vacuum pump. Observe low-side gauge. Any loss of vacuum within 5 minutes indicates a system leak. Perform leak testing procedure. See LEAK TESTING. Repair system as necessary and repeat evacuation procedure.

GENERAL MOTORS

Manufacturer recommends using A/C Refrigerant Recovery, Recycling & Recharging (ACR4) System (J-39500). The ACR4 system has one filtering cycle during recovery, plus an automatic multiple pass filtering during evacuation cycle. Follow manufacturer's instructions provided with ACR4 equipment being used.

JEEP

1) Connect approved recovery/recycling equipment and manifold gauge set. Fully open manifold gauge set low-side and high-side valves, and start vacuum pump. Operate vacuum pump until low-side vacuum reading of 26 in. Hg or more. Close all valves and turn vacuum pump off. Observe vacuum gauge, go to next step.

2) If A/C system maintains specified vacuum for 5 minutes, open low-side and high-side valves, restart vacuum pump and operate for an additional 10 minutes. Close all valves. Turn vacuum pump off

and disconnect pump.

3) If A/C system cannot get to or maintain specified vacuum, check for a defective vacuum pump or leak in A/C system or gauge set. See LEAK TESTING. Repair or replace components as necessary.

CHARGING A/C SYSTEM

CAUTION: During charging of A/C system, refrigerant container must be in an upright position. If refrigerant container is upside-down, compressor may be damaged by liquid refrigerant drawn into A/C system.

DAIMLERCHRYSLER CORP.

Breeze, Cirrus & Stratus (Manifold Gauge Set Method)

1) Attach clamp-on Thermocouple (80PK-1A) to liquid line, as close to condenser outlet as possible. Attach manifold gauge set to vehicle.

2) Set parking brake, and place transaxle in Park. Start engine and allow to idle. Set A/C controls to outside air, panel mode, full cool, and high blower speed. Turn A/C on, and open windows. Operate system for a few minutes to allow system to stabilize.

3) Place cardboard over front grille area, to block airflow through part of condenser, to set A/C pressure to 260 psi (18.3 kg/cm²). This will stop cooling fans from alternating speeds, and maintain constant pressure.

4) Record temperature reading at liquid line and discharge pressure reading on gauges. Compare readings with values in REFRIGERANT CHARGE LEVEL table.

5) Depending on system charge condition, corrections are made 2 ounces at a time. Each time a correction is made, recheck readings to ensure proper charge. For system refrigerant capacity, see REFRIGERANT OIL & REFRIGERANT SPECIFICATIONS article.

REFRIGERANT CHARGE LEVEL

AA
Liquid Line Temp. - °F (°C) (1) Discharge Pressure - psi (kg/cm²)

40 (4.4)	53-75 (3.7-5.3)
60 (15.6)	81-104 (5.7-7.3)
80 (26.7)	111-142 (7.8-10.0)
100 (37.8)	156-194 (11.0-13.6)
120 (48.9)	208-259 (14.6-18.2)
140 (60.0)	272-331 (19.1-23.3)
160 (71.1)	353-420 (24.8-29.5)
180 (82.2)	447-516 (31.4-36.3)

(1) - When pressure is lower than specified, system is undercharged.
When pressure is higher than specified, system is overcharged.

AA

Concord, Intrepid, LHS, PT Cruiser & 300M

Manufacturer recommends using refrigerant recovery/recycling equipment which meets SAE standard J1991 or J2210. Always follow

A/C SYSTEM GENERAL SERVICING

ABC123

Entire Article
2000 Chevrolet Camaro

instructions provided with recovery/recycling equipment being used.

Neon, Sebring Sedan, 2001 Stratus Sedan, & Sebring Convertible

1) Ensure A/C system has no leaks and has been evacuated. See EVACUATING A/C SYSTEM and

LEAK TESTING. If using a separate vacuum pump, close all valves before disconnecting pump. Connect approved recovery/recycling equipment and manifold gauge set to A/C service ports.

2) Measure specified quantity of refrigerant and oil. See REFRIGERANT OIL & REFRIGERANT SPECIFICATIONS article. Refer to recovery/recycling equipment operating instructions. Ensure engine is off. Open suction and discharge valves. Open equipment charge valve to allow refrigerant to flow into A/C system. When refrigerant transfer has stopped, close valves.

3) If all of refrigerant did not transfer, set parking brake and transmission to Park (A/T) or Neutral (M/T). Start engine and allow to idle at approximately 700 RPM. Close all windows and turn A/C on. Set A/C controls to 100 percent outside air, panel mode, blower motor to high speed and temperature to maximum cold.

4) If compressor does not engage, check clutch operation and control circuit. Perform repairs as necessary. Open suction valve (low pressure) to allow remaining refrigerant to transfer to A/C system. DO NOT open discharge (high pressure) valve at this time.

5) When transfer is complete, close all valve and ensure A/C system is operating properly. Disconnect recovery/recycling equipment, manifold set and replace service port caps.

All Other Models

Ensure A/C system has been checked for leaks and evacuated. See EVACUATING A/C SYSTEM and

LEAK TESTING. Charge A/C system to specifications. For system refrigerant capacity, see REFRIGERANT OIL & REFRIGERANT SPECIFICATIONS article.

FORD MOTOR CO.

1) If using approved Recovery/Recycling/Charging Center (023-00105 or 023-00150), connect to high-side and low-side service valves. See SYSTEM SERVICE VALVES under SYSTEM SERVICE VALVES. Operate charging center according to manufacturer's instructions. Charge system with specified amount of refrigerant and refrigerant oil. See REFRIGERANT OIL & REFRIGERANT SPECIFICATIONS article. Check amount of refrigerant oil in system before adding oil. See COMPRESSOR REFRIGERANT OIL CHECKING article.

2) If using manifold gauge set, connect to high-side and low-side service valves. See SYSTEM SERVICE VALVES under SYSTEM SERVICE VALVES. Connect 2 hoses with shutoff valves to manifold gauge set center port. Connect one hose to vacuum pump and other hose to refrigerant container. Weight of refrigerant container before and after charging can be used to determine amount of refrigerant drawn into system. Using vacuum pump, purge air from center hoses.

3) Fully open manifold gauge set low-side valve and refrigerant container valve to allow refrigerant to enter A/C system.

ABC123

Entire Article
2000 Chevrolet Camaro

When no more refrigerant is being drawn into A/C system, start engine and allow to idle. Select MAX A/C, set blower motor speed to maximum and allow remaining refrigerant to be drawn into A/C system.

NOTE: When ambient air temperature is high, it may be necessary to use an external cooling fan to blow air through condenser and radiator.

4) When proper amount of refrigerant has been added, close refrigerant container valve. Allow any refrigerant remaining in hose to be drawn into A/C system. When low-side pressure decreases to about 30 psi (2.1 kg/cm²), close center valve on manifold gauge set. Ensure A/C system is operating properly. Disconnect manifold gauge set. Install service port caps. Check system for leaks. See LEAK TESTING.

GENERAL MOTORS

Manufacturer recommends using A/C Refrigerant Recovery, Recycling & Recharging (ACR4) System (J-39500). The ACR4 system has one filtering cycle during recovery, plus an automatic multiple pass filtering during evacuation cycle. Follow manufacturer's instructions provided with ACR4 equipment being used.

JEEP

Connect recovery/recycling equipment, meeting SAE standard J1991 or J2210, to vehicle. Charge A/C system to specifications using equipment manufacturer's instructions.

LEAK TESTING

WARNING: R-134a service equipment or vehicle A/C system should not be pressure tested or leak tested using compressed air. A mixture of 60% air and R-134a refrigerant can be combustible at elevated pressures. This mixture is potentially dangerous and may result in a fire and/or an explosion causing injury and/or property damage.

TYPES OF LEAK DETECTORS

Bubble Solution Detector

This is a solution applied externally at suspected leak points. Leaking refrigerant will cause detector to form bubbles and foam. A soap and water solution also works well.

Dye Solution

This is a colored solution that may be introduced into A/C system. Dye will show up and color components at leak points. Some manufacturers offer refrigerant containing a Red dye. This dye-containing refrigerant is installed by normal charging procedures. Other dye solutions are visible with a Black Light only.

NOTE: All 2001 model year GM passenger vehicles have a fluorescent leak detection tracer dye added to the A/C system. An

underhood A/C charge label (when available) will have CONTAINS REFRIGERANT DYE on the label. Not all vehicles with the dye will have the new A/C charge label.

NOTE: Ford Motor Co. vehicles with A/C system fluorescent leak detection tracer dye will have a Green "X" on the accumulator.

Fluorescent Leak Detection

One of the most effective ways to detect a leak in an A/C system is with fluorescent leak detection tracer dye. If fluorescent dye has been added during vehicle production, additional refrigerant dye for leak detection is not required. Dye added to A/C system during production will remain unless removed during a flushing process. Dye mixes with refrigerant oil, not refrigerant. On Ford vehicles, dye is visible using a 120 watt UV spot light. On GM vehicles, dye is visible using Yellow glasses and a High Intensity Black Light (J28428-E).

Electronic Leak Detector

This instrument will draw in any leaking refrigerant through a test probe, and then sound an audible signal or create a flashing light if refrigerant is found. It is the most sensitive of the leak detectors used. Leak detectors are sensitive to windshield washing solutions, many solvents and cleaners, and some adhesives. Ensure surfaces near test areas are clean and dry to prevent false signal or detector damage. Liquids ingested into detector will damage detector. See Fig. 24.

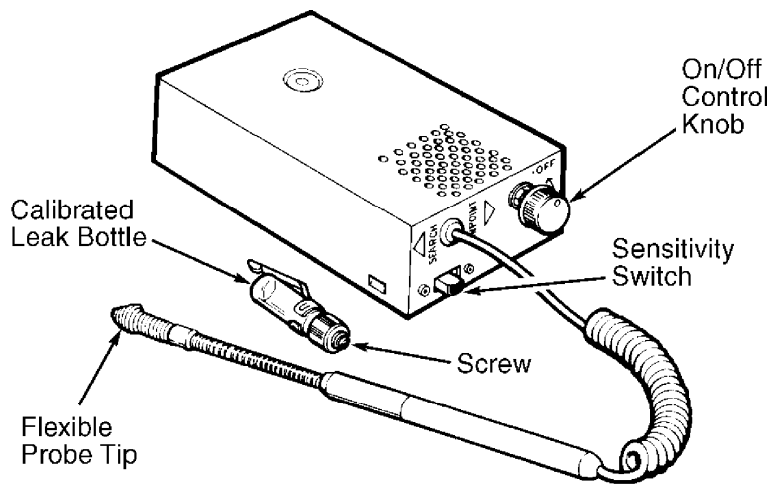

95D17643

Fig. 24: Electronic Leak Detector

PREPARATION FOR LEAK TESTING

Connect manifold gauge set to A/C system. Ensure low-side and high-side gauge set valves are closed. Check system pressure. Pressure should be at least 50 psi (3.5 kg/cm²). If system is empty, evacuate A/C system and apply 28 in. Hg of vacuum. If system holds vacuum for 15 minutes, there most likely are no leaks present. If low, add just

enough refrigerant (about 10 ounces) to bring system to 50 psi (3.5 kg/cm²).

Ensure all joints, connections, and fittings are free of oil dirt and other contaminants. Using a refrigerant leak detector, check all refrigerant line connections for leaks. Check condenser and compressor seal area.

Start engine and allow to idle. Operate A/C system for about 5 minutes. Set A/C controls to outside air, and high blower speed. Turn A/C on, and open vehicle windows. Turn engine off and wait 2-7 minutes. Refrigerant is heavier than air. Always check for leaks at bottom of refrigerant lines and components. Refrigerant oil will leak with refrigerant. Visually check all connections and compressor clutch area for oil stains. If compressor shaft seal is leaking, a fresh oil streak will normally be seen on underside of hood, above compressor clutch.

Always perform leak testing after A/C service. Move refrigerant leak detector slowly to check for leaks, as leaks will not be detected if leak testing is performed too quickly.

BUBBLE DETECTOR LEAK TESTING PROCEDURE

This leak detection method is recommended when it is impossible or difficult to determine the exact location of the leak using other methods. Although commercial bubble detectors are more effective, household soap solutions may be used.

Using dauber that comes with commercial soap solution, apply solution to all joints, connections, fittings or controls where a leak might be suspected. If high-suds household solutions are used, apply with a small brush. Wherever bubbles form, leaks are present and must be repaired. Check entire system, as there may be more than one leak.

ELECTRONIC LEAK TESTING PROCEDURE

NOTE: Some electronic leak detectors will function on only R-12 systems or on only R-134a systems, and some will function on both R-12 and R-134a systems. Familiarize yourself with tester being used and know what type of system you are leak testing.

Electronic leak detectors should be used in well ventilated areas. Avoid using around explosive gases. Always follow manufacturer's instructions for specific tester being used. If none are available, proceed as follows:

- 1) Turn all controls and detector sensitivity knob to OFF position or zero setting. Connect leak detector to an approved source of power. Turn switch to ON position, and allow unit to warm up for approximately 5 minutes.
- 2) Check operation of tester by positioning probe in a reference source where refrigerant is known to be present in small

amounts. Adjust controls and sensitivity knob until detector reacts properly. Move probe away from refrigerant source and reaction should stop. If reaction continues, adjust sensitivity knob to a lower setting.

3) When tester reacts properly, leak test A/C system by moving probe under all components, fittings and connections. Keep probe moving. To check evaporator, insert probe into drain tube opening or a heater duct. DO NOT allow probe to contact refrigerant or refrigerant oil. When leaks are found, repair as necessary. Keep in mind, there may be more than one leak.

DYE SOLUTION LEAK TESTING PROCEDURES

CAUTION: Dye-charged refrigerant cans are available to be used as internal leak detectors. Use of this type of solution may void some manufacturer's warranties. Be sure to check with A/C system manufacturer concerning use of dye-charged leak detectors. Dyes which work in R-12 systems will not work in R-134a systems.

The following procedure is for introducing a dye solution, not dye-charged refrigerant, into A/C system.

1) Connect manifold gauge set to A/C system in a normal manner. Remove center hose from manifold gauge set, and replace it with a short piece (6" long) of 1/4" tubing using two 1/4" flare nuts. Connect a container of dye solution to tubing.

2) Connect one end of gauge set center hose to dye solution container. Connect a container of refrigerant to other end of hose. Operate engine at idle. Set A/C system for maximum cooling. Slowly open low-side hand valve to allow dye solution to enter system.

3) Charge system to at least 50 percent capacity. Operate system for 15 minutes, and then shut off both A/C system and engine. Check all connections for signs of colored dye solution. Check vehicle again 24 hours later. If leaks are found, repair as necessary.

FLUORESCENT DYE LEAK TESTING PROCEDURES

CAUTION: Even though refrigerant dye is non-toxic and water soluble, wearing rubber gloves will prevent hands from glowing when under Ultraviolet (UV) Black Light. Wash hands frequently and thoroughly, using a dye cleaner or soap and water before entering vehicle, or touching other underhood components. Refrigerant dye will transfer from hands to anything touched. Refrigerant dye is suspended in refrigerant oil. Refrigerant oil will stain paint if it comes into contact with and be highlighted by refrigerant dye. Use R-134a Leak Dye Cleaner (J43872) to clean area around fittings and leak areas.

CAUTION: Fluorescent dye, when mixed with PAG oil, remains detectable in A/C system for 2 years. DO NOT exceed specified quantity of refrigerant oil in system. Use only 0.25 ounce of refrigerant oil charge.

A/C SYSTEM GENERAL SERVICING

ABC123

Entire Article
2000 Chevrolet Camaro

NOTE: Fluorescent leak detection method is intended to be used in conjunction with an electronic leak detection method, to pinpoint smaller leaks. Fluorescent dye takes time to work. Depending on leak rate, dye could take up to 7 days to become visible after installation into A/C system.

NOTE: After refrigerant dye is installed into A/C system, complete refrigerant leak detection notice sticker (supplied with dye package) and place next to underhood charge label.

1) Start engine and allow to idle. Turn A/C system on and controls to maximum cold position. Ensure compressor clutch is engaged. If compressor clutch stays engaged at idle, low side refrigerant pressure is sufficient to check for a leak. If necessary, charge A/C system so compressor clutch will operate.

NOTE: A/C refrigerant system does not have to be evacuated and/or opened to install leak detection dye when using tracer dye injector.

2) If A/C system is charged, install fluorescent leak detection dye using R-134a A/C tracer dye injector. Follow dye injector manufacturer instructions. If A/C system is discharged, add dye to replacement component with specified amount of refrigerant oil.

3) After installing dye, clean low side fitting to remove any residue, using fluorescent dye cleaner or general purpose oil solvent. Observe and record ambient air temperature and humidity. Place thermometer in center A/C outlet duct.

4) Start engine. Turn A/C system on, and controls to maximum cold position. Increase engine speed to 1500 RPM. After approximately 5 minutes, record outlet temperature displayed on center A/C outlet duct thermometer. If outlet temperature is at least 20°F (11°C) colder than ambient temperature, A/C system is operating properly.

5) Turn engine off. Check for refrigerant leaks using an electronic leak detector. See ELECTRONIC LEAK TESTING PROCEDURE. Perform repairs as necessary. If no leaks are found, go to next step.

6) Using Leak Detection Lamp Kit (J42220) UV lamp and Yellow glasses, slowly pan A/C system with UV lamp directed toward all possible leak areas. When a leak is found, fluorescent dye, when viewed through Yellow glasses and highlighted with UV lamp, will glow Light Green or Yellow/Green.

7) Leak detection dye mixes with refrigerant PAG oil. Therefore, extremely small leaks may be pressure, temperature or vibration sensitive and may not be active during a 5 minute test. It may be necessary to request vehicle be returned for further testing in 3 to 5 days. Because detection dye and PAG oil are water soluble, vehicles driven in rain, through sprinkler puddles, etc., may experience leak detection problems.

8) Perform repairs as necessary. Clean A/C system components, especially repaired area, using a Leak Dye Cleaner (J43872) or water until dye can no longer be detected. Start engine and allow to idle. Operate A/C system at maximum cold settings for 5 minutes, and recheck for leaks.

A/C SYSTEM GENERAL SERVICING

ABC123

Entire Article

2000 Chevrolet Camaro

A00091424

END OF ARTICLE